



CERTIFIED SIM RACING



HYBRID

COCKPIT

Assembly Guide

Recommended
1-2 People



Read Instructions
10 Minutes

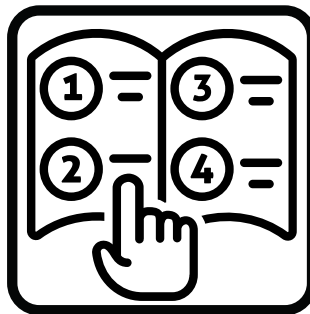

Assembly Time
60-120 Minutes

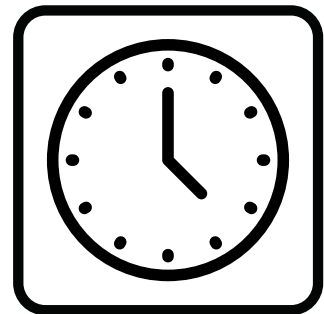

gtomega.com

TABLE OF CONTENT

PAGE 1

NOTICES

PAGE 2

WHAT'S IN THE BOX

PAGE 3 - 7

ASSEMBLY INSTRUCTIONS



Need Help? We're here for you! [Contact our support team:](#)



WARNING



Children should not use unsupervised



Do not exceed load capacity of **200KG**



Do not stand on the Cockpit



Take care when assembling



Do not push or pull Cockpit



FAILURE TO COMPLY WITH OR OBSERVE ALL ASSEMBLY, SAFETY, AND OPERATION INSTRUCTIONS REGARDING THE USE OF THIS PRODUCT MAY RESULT IN **PROPERTY DAMAGE** OR **BODILY INJURY**.

- This document contains important safety regulations. Any non-conforming use may result in personal injury or mechanical damage.
- Please read this user manual carefully before use as it provides key information about safety, use, and assembly of the **HYBRID Cockpit**.
- Ensure that you have received all parts according to the part checklist prior to installation. If any parts are missing or faulty, contact the GT Omega support team for replacements.
- **Do not** over tighten the screws during installation.
- This product contains small items that could be a choking hazard if swallowed. Keep these items away from children.
- This product is designed for indoor use only. Using the product outdoors could lead to product failure and personal injury.
- Alteration or modification of any factory components outlined in the checklist will automatically void your warranty.
- Place the **HYBRID Cockpit** away from corrosive gas, water and dusty environments.

The **HYBRID Cockpit** is designed for indoor use and dry work areas only. Under no circumstances does the manufacturer accept warranty claims or liability claims for damages caused from improper use or handling.



WHAT'S IN THE BOX

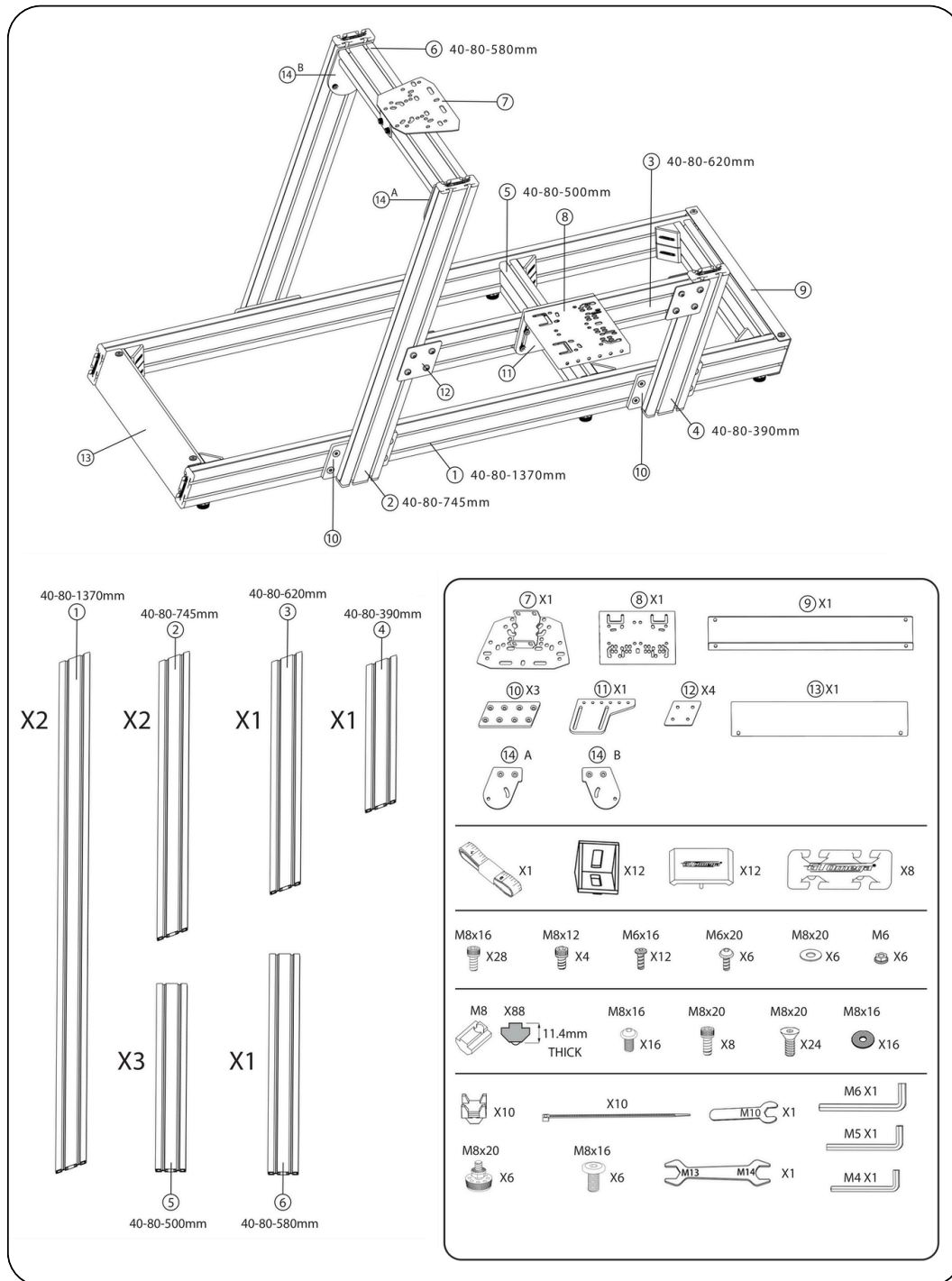

If you are missing any parts, please contact our customer support team who can assist.

IMPORTANT

Please read the instructions carefully and **in full** before starting assembly. This will help prevent mistakes and the need to disassemble parts later.

1

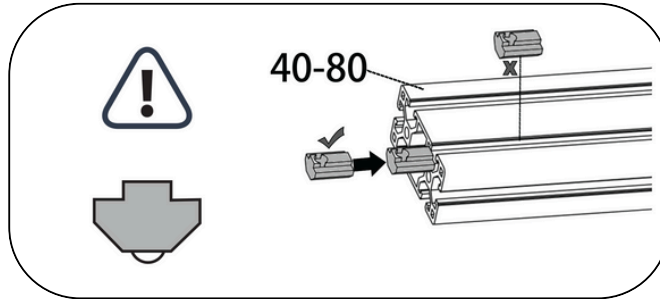

Insert the T-nuts from the end of the profile channels. Do not try to drop them in from above, they must slide in from the end.

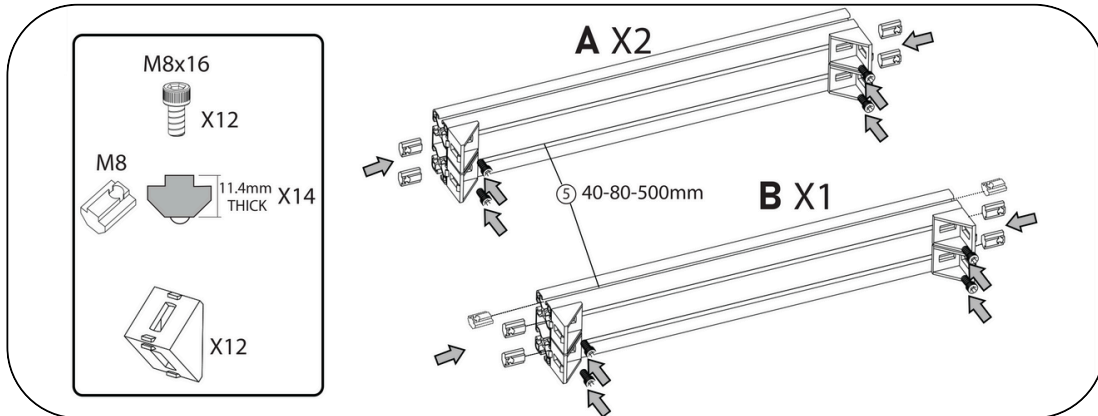

Attach corner brackets to the short profile sections using bolts and T-nuts.

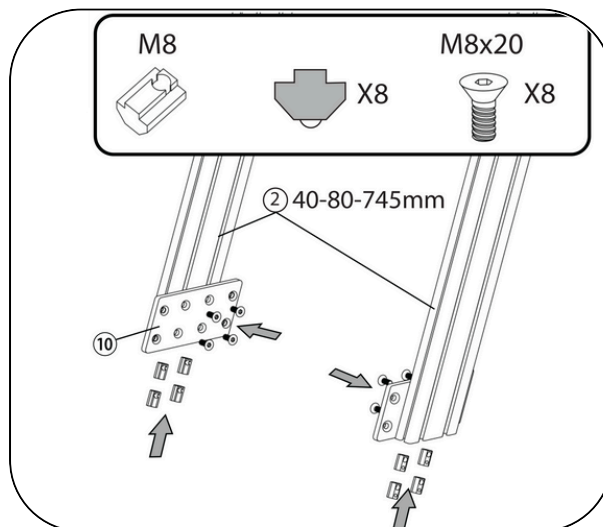

Connect the sandwich plates to the base of the upright sections using bolts and T nuts.

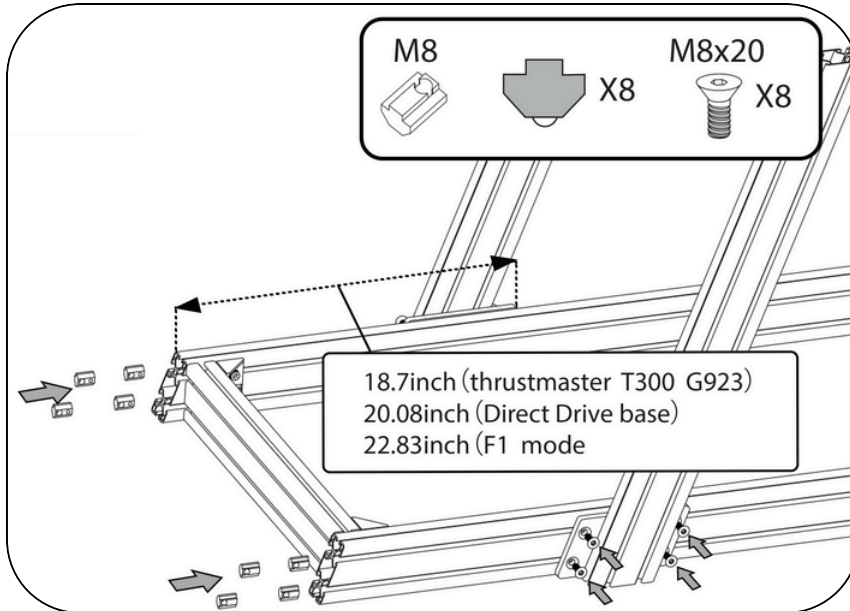

Connect the front section you built between the long pieces of profile then connect the uprights to the outside of the cockpit frame.

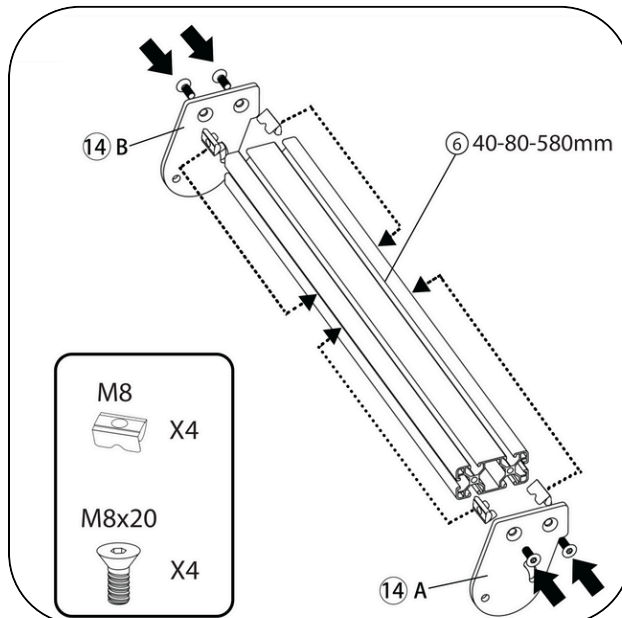

Begin building the upper frame by attaching the mounting brackets on either side of the short profile.

Be sure to place extra T nuts in the front and rear facing sides of the wheel deck.

ASSEMBLY INSTRUCTIONS

2

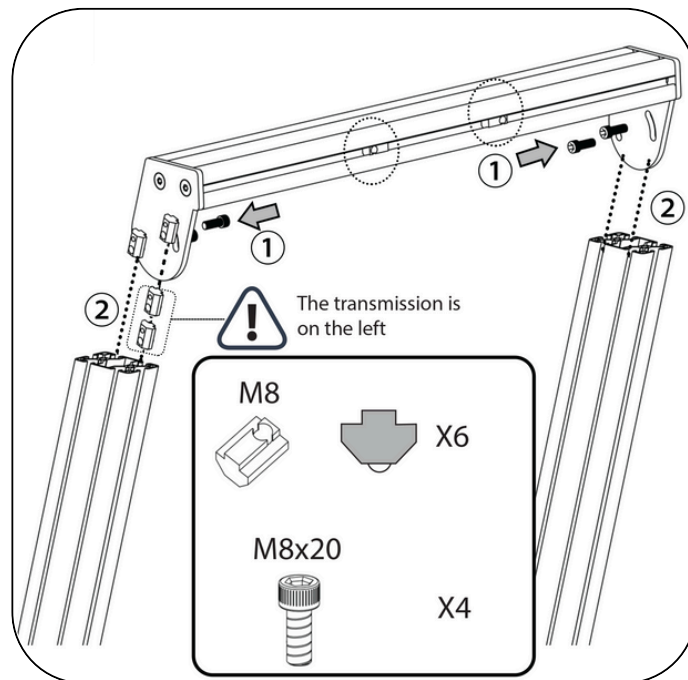

Line up your t nuts in the uprights and connect the upper frame to the uprights.

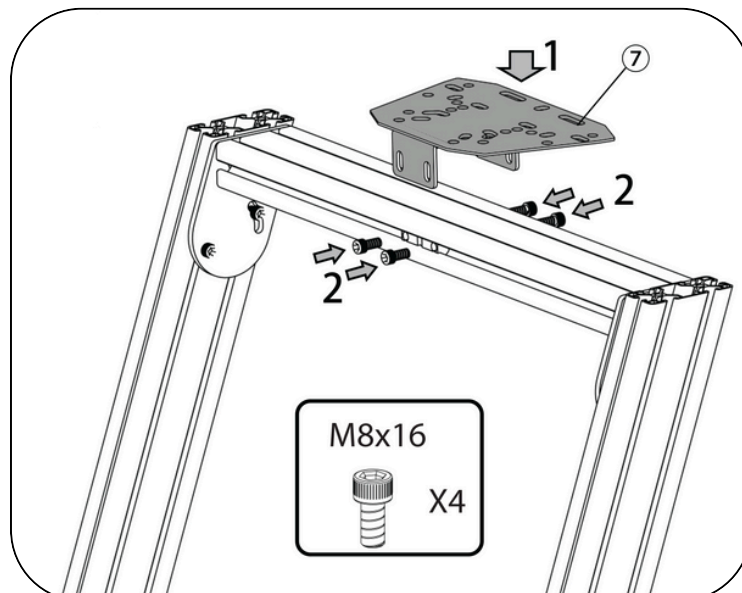

Connect your wheel deck to the upper frame using bolts. It may be easier to mount your wheel base before you do this.

ASSEMBLY INSTRUCTIONS

2

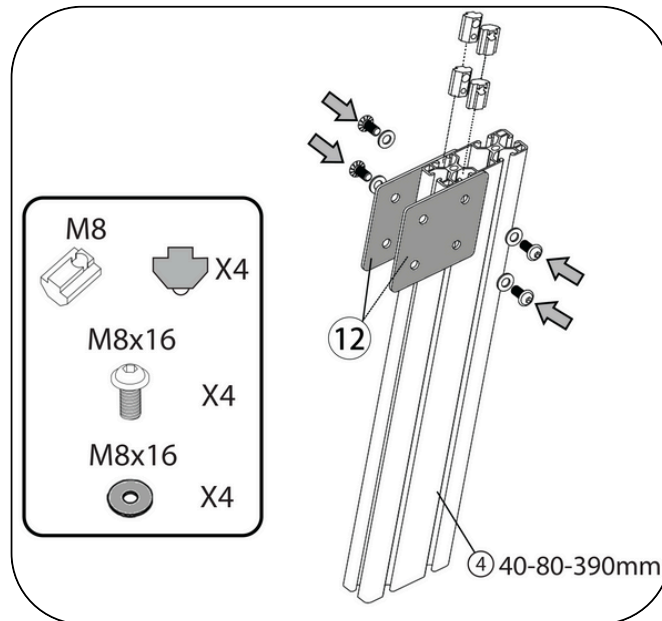

Begin construction your side bracket by adding the joining plates to one end of the profile.

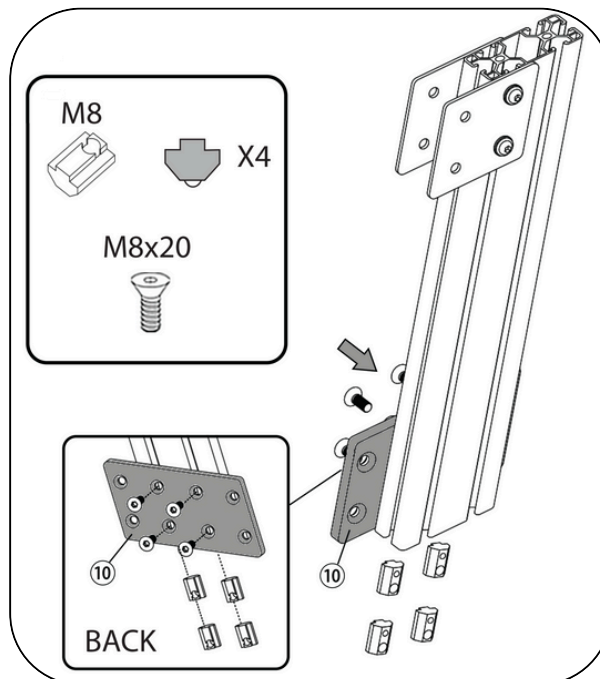

Then add a sandwich plate to the opposite side.

ASSEMBLY INSTRUCTIONS

2

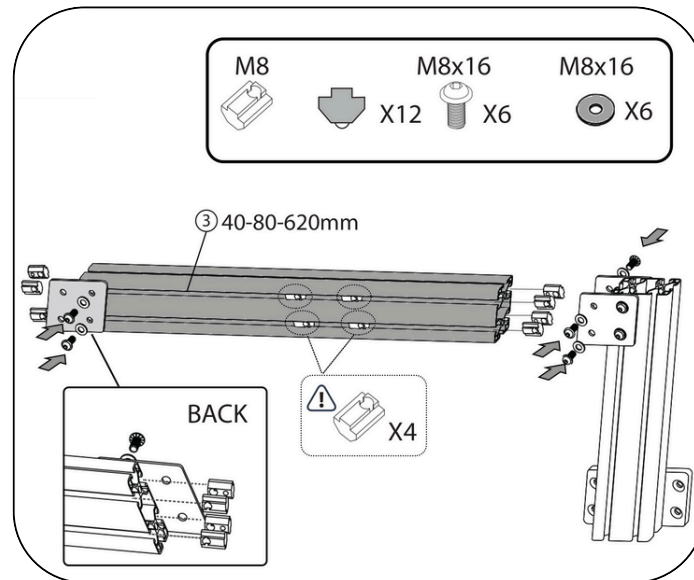

Complete the side bracket by connecting the other piece of profile and adding a joining plate to the opposite side.

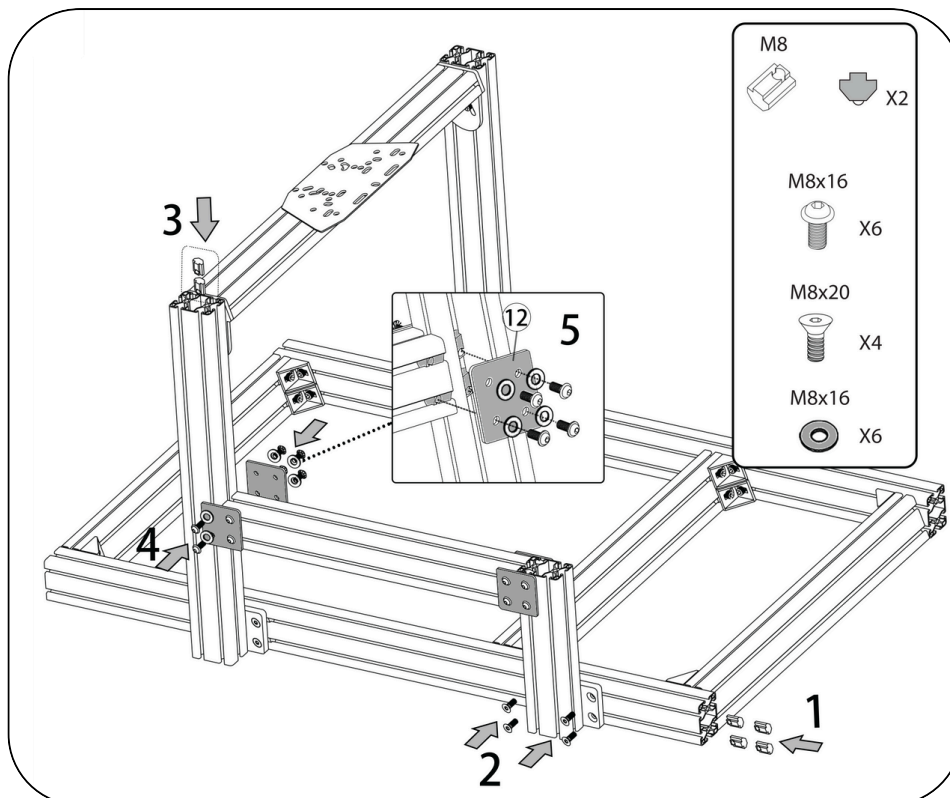

Connect the side bracket to the rest of the cockpit frame using the connector plates.

ASSEMBLY INSTRUCTIONS

3

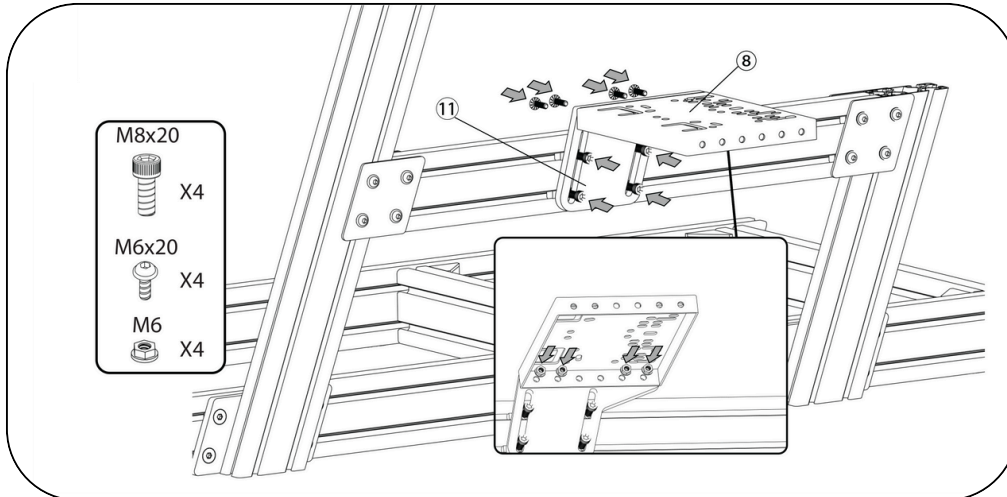

Connect the shifter plate to the outside of the side bracket. Leave this loose to help adjust positioning before bolting firmly into place.

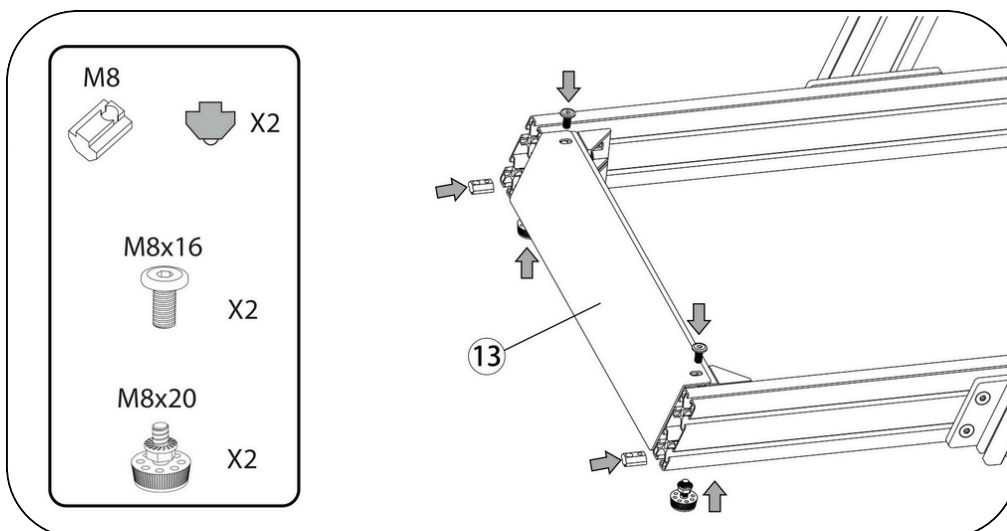

Add the plate to the front of your cockpit and then the feet on the underside

ASSEMBLY INSTRUCTIONS

4

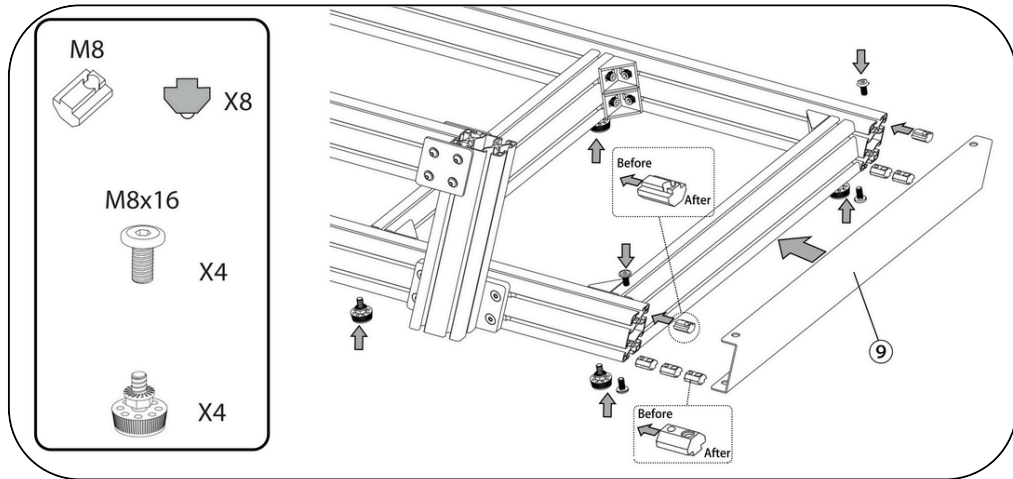

Repeat these steps for the rear side

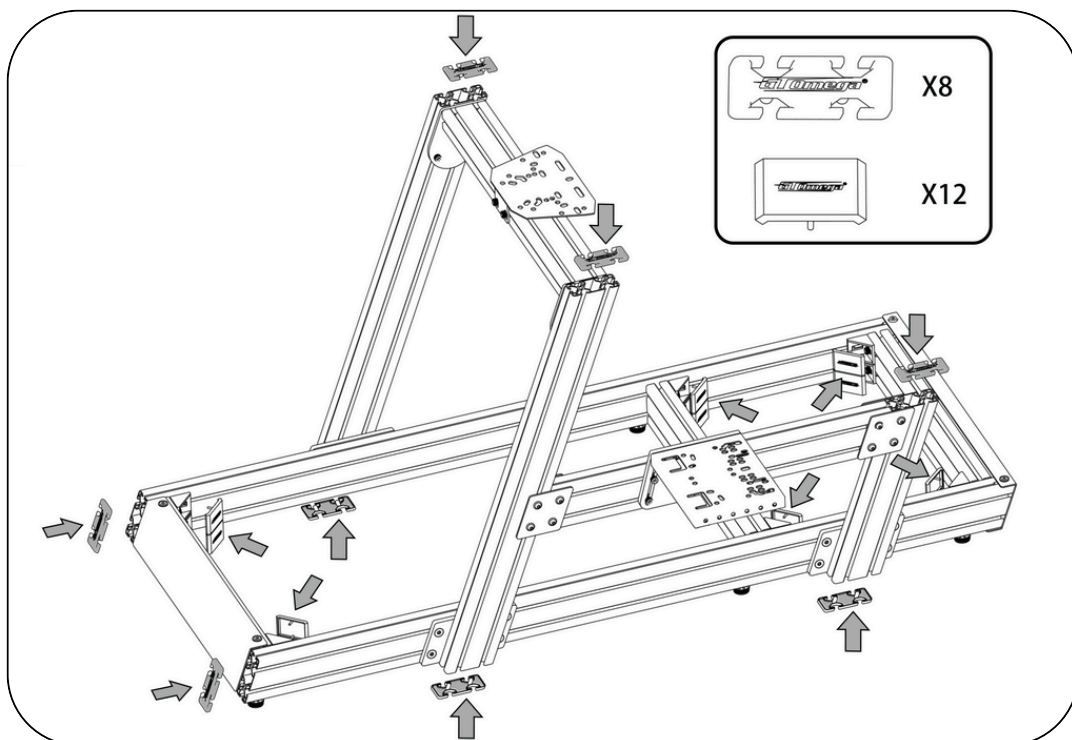

Complete your Hybrid cockpit by placing the end caps and corner caps on the exposed ends and corner pieces

Unlock the full potential of your

HYBRID COCKPIT



PRIME Keyboard Tray

This practical attachment gives you the control you need without ever having to leave your seat. The PRIME keyboard tray can be mounted at any height on the left- or right-side of your cockpit.



PRIME Caster Wheels

Highly mobile wheels with ultra-durable construction. These heavy-duty caster wheels come in a set of 6. Height adjustable rubber feet protect your floors and help you keep your cockpit balanced.



Simulator Floor Mat

The Simulator Floor Mat is designed to provide a slip and vibration free surface for your cockpit. The perfect finishing touch for any racing set up.



Simulator Monitor Stand

The Simulator Monitor Stand offers stable, eye-level screen placement with no vibrations. Upgradable to triple and quadruple screen setups. Strong, adjustable, and built to last.

Bundle and Save!

Save **up to 17%** on your sim racing accessories when you build your own accessory bundles.

[View Sim Accessory Bundles](#)